

WORX

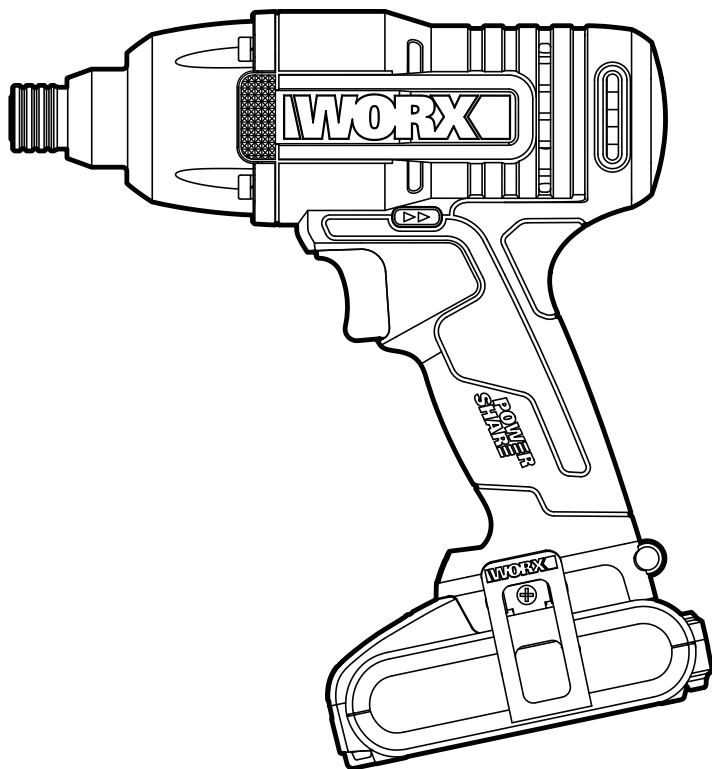

SAFETY AND OPERATING MANUAL

ORIGINAL INSTRUCTIONS

Cordless Impact Driver WX291 WX291.X

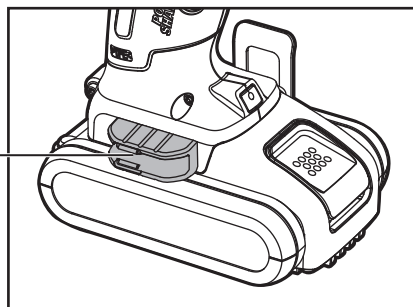
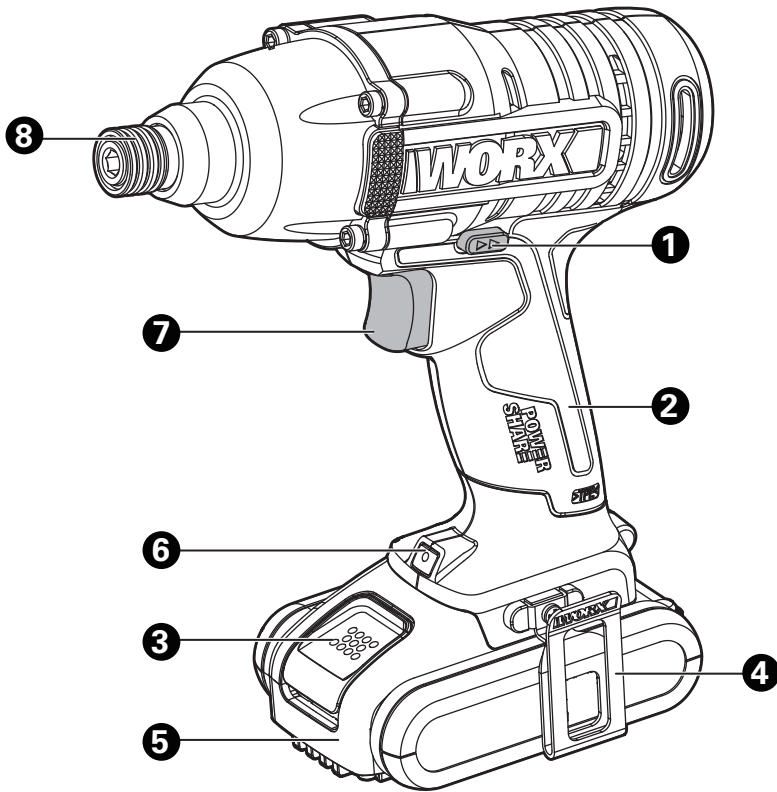

Cordless Impact Driver **WX291 WX291.X**

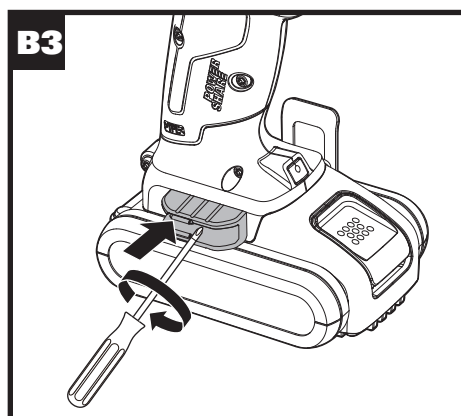
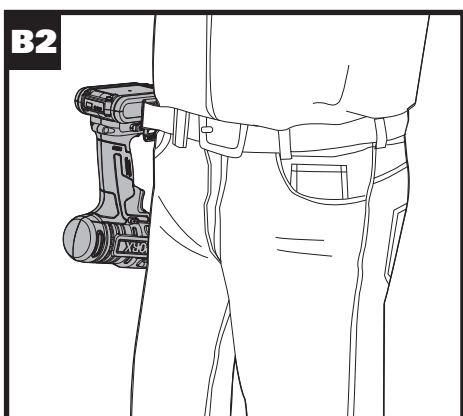
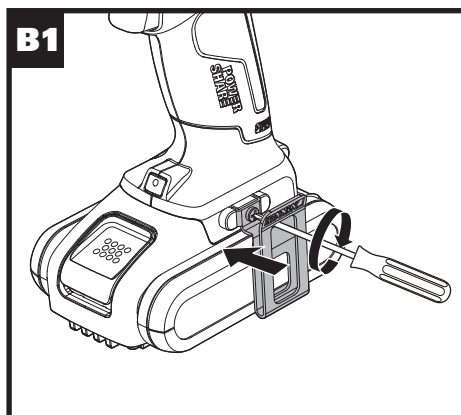
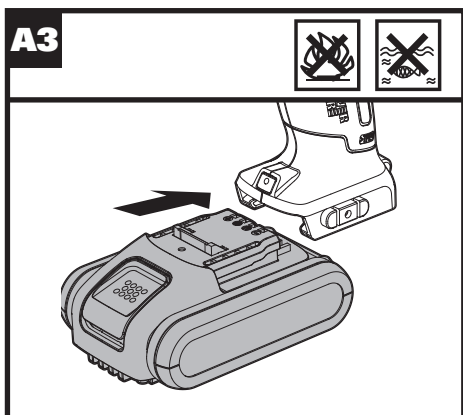
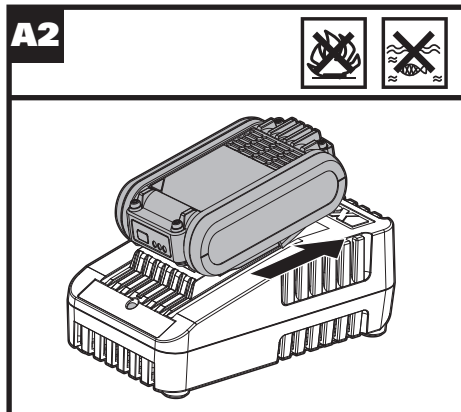
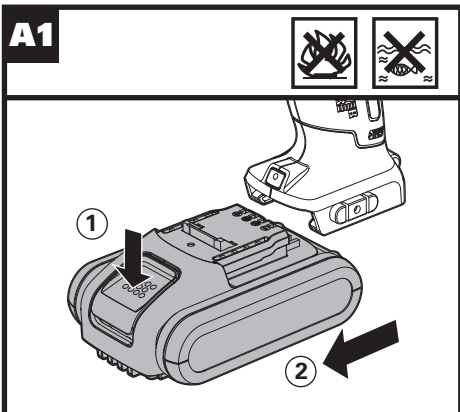

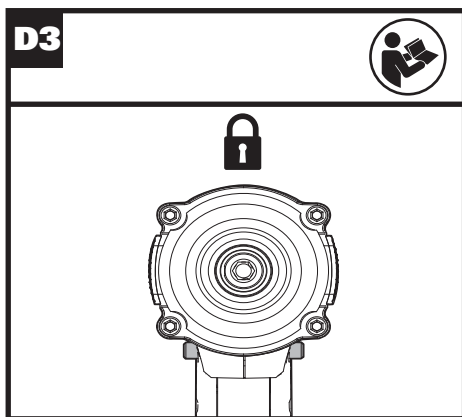
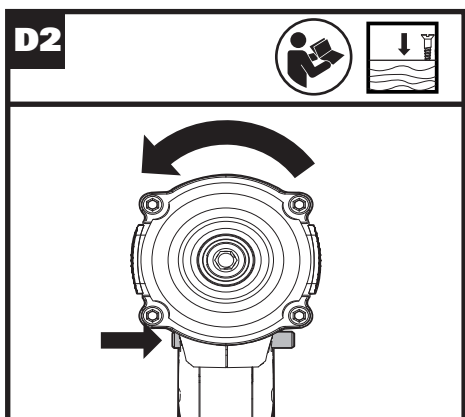
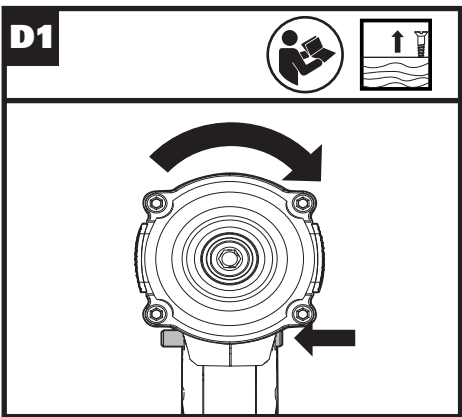
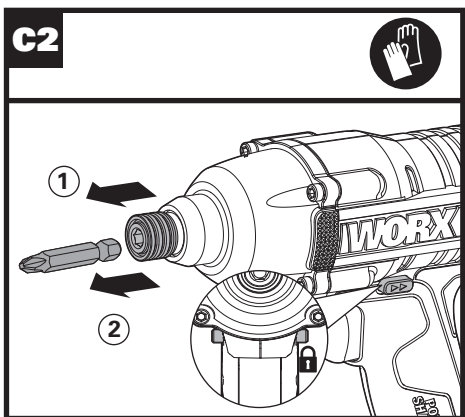
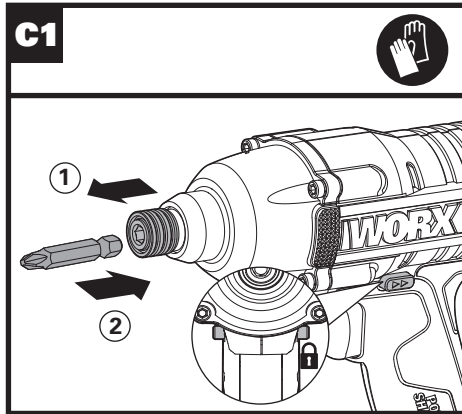
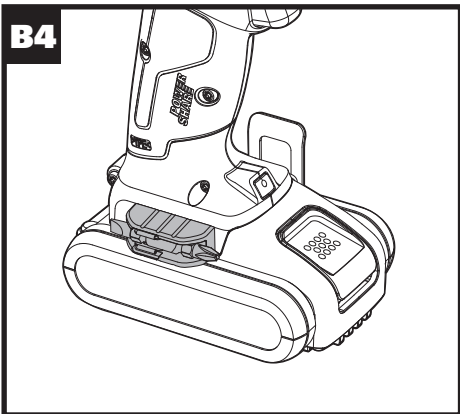

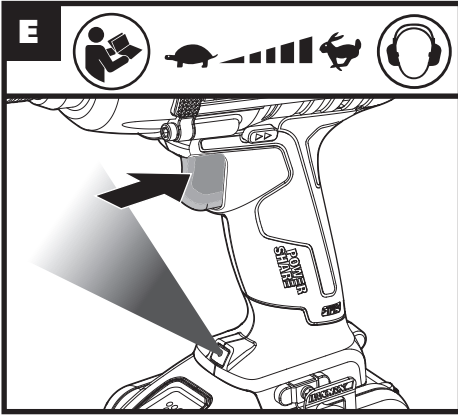

PRODUCT SAFETY

GENERAL POWER TOOL

SAFETY WARNINGS

 **WARNING:** Read all safety warnings, instructions, illustrations and specifications provided with this power tool. Failure to follow all instructions listed below may result in electric shock, fire and/or serious injury.

Save all warnings and instructions for future reference.

The term "power tool" in the warnings refers to your mains-operated (corded) power tool or battery-operated (cordless) power tool.

1) Work area safety

- a) **Keep work area clean and well lit.** Cluttered or dark areas invite accidents.
- b) **Do not operate power tools in explosive atmospheres, such as in the presence of flammable liquids, gases or dust.** Power tools create sparks which may ignite the dust or fumes.
- c) **Keep children and bystanders away while operating a power tool.** Distractions can cause you to lose control.

2) Electrical safety

- a) **Power tool plugs must match the outlet. Never modify the plug in any way. Do not use any adapter plugs with earthed (grounded) power tools.** Unmodified plugs and matching outlets will reduce risk of electric shock.
- b) **Avoid body contact with earthed or grounded surfaces, such as pipes, radiators, ranges and refrigerators.** There is an increased risk of electric shock if your body is earthed or grounded.
- c) **Do not expose power tools to rain or wet conditions.** Water entering a power tool will increase the risk of electric shock.
- d) **Do not abuse the cord. Never use the cord for carrying, pulling or unplugging the power tool. Keep cord away from heat, oil, sharp edges or moving parts.** Damaged or entangled cords increase the risk of electric shock.
- e) **When operating a power tool outdoors, use an extension cord suitable for outdoor use.** Use of a cord suitable for outdoor use reduces the risk of electric shock.
- f) **If operating a power tool in a damp location is unavoidable, use a residual current device (RCD) protected supply.** Use of an RCD reduces the risk of electric shock.

3) Personal safety

- a) **Stay alert, watch what you are doing and use common sense when operating a power tool. Do not use a power tool while you are tired or under**

the influence of drugs, alcohol or medication.

A moment of inattention while operating power tools may result in serious personal injury.

- b) **Use personal protective equipment. Always wear eye protection.** Protective equipment such as dust mask, non-skid safety shoes, hard hat, or hearing protection used for appropriate conditions will reduce personal injuries.
 - c) **Prevent unintentional starting. Ensure the switch is in the off-position before connecting to power source and/or battery pack, picking up or carrying the tool.** Carrying power tools with your finger on the switch or energising power tools that have the switch on invites accidents.
 - d) **Remove any adjusting key or wrench before turning the power tool on.** A wrench or a key left attached to a rotating part of the power tool may result in personal injury.
 - e) **Do not overreach. Keep proper footing and balance at all times.** This enables better control of the power tool in unexpected situations.
 - f) **Dress properly. Do not wear loose clothing or jewellery. Keep your hair and clothing away from moving parts.** Loose clothes, jewellery or long hair can be caught in moving parts.
 - g) **If devices are provided for the connection of dust extraction and collection facilities, ensure these are connected and properly used.** Use of dust collection can reduce dust-related hazards.
 - h) **Do not let familiarity gained from frequent use of tools allow you to become complacent and ignore tool safety principles.** A careless action can cause severe injury within a fraction of a second.
-
- 4) **Power tool use and care**
 - a) **Do not force the power tool. Use the correct power tool for your application.** The correct power tool will do the job better and safer at the rate for which it was designed.
 - b) **Do not use the power tool if the switch does not turn it on and off.** Any power tool that cannot be controlled with the switch is dangerous and must be repaired.
 - c) **Disconnect the plug from the power source and/or remove the battery pack, if detachable, from the power tool before making any adjustments, changing accessories, or storing power tools.** Such preventive safety measures reduce the risk of starting the power tool accidentally.
 - d) **Store idle power tools out of the reach of children and do not allow persons unfamiliar with the power tool or these instructions to operate the power tool.** Power tools are dangerous in the hands of untrained users.
 - e) **Maintain power tools and accessories. Check for misalignment or binding of moving parts, breakage of parts and any other condition that may affect the power tool's operation. If damaged, have the power tool repaired before use.** Many accidents are caused by poorly maintained power tools.

- f) **Keep cutting tools sharp and clean.** *Properly maintained cutting tools with sharp cutting edges are less likely to bind and are easier to control.*
 - g) **Use the power tool, accessories and tool bits etc. in accordance with these instructions, taking into account the working conditions and the work to be performed. Use of the power tool for operations different from those intended could result in a hazardous situation.**
 - h) **Keep handles and grasping surfaces dry, clean and free from oil and grease.** *Slippery handles and grasping surfaces do not allow for safe handling and control of the tool in unexpected situations.*
- 5) Battery tool use and care**
- a) **Recharge only with the charger specified by the manufacturer.** *A charger that is suitable for one type of battery pack may create a risk of fire when used with another battery pack.*
 - b) **Use power tools only with specifically designated battery packs.** *Use of any other battery packs may create a risk of injury and fire.*
 - c) **When battery pack is not in use, keep it away from other metal objects, like paper clips, coins, keys, nails, screws or other small metal objects, that can make a connection from one terminal to another.** *Shorting the battery terminals together may cause burns or a fire.*
 - d) **Under abusive conditions, liquid may be ejected from the battery; avoid contact. If contact accidentally occurs, flush with water. If liquid contacts eyes, additionally seek medical help.** *Liquid ejected from the battery may cause irritation or burns.*
 - e) **Do not use a battery pack or tool that is damaged or modified.** *Damaged or modified batteries may exhibit unpredictable behaviour resulting in fire, explosion or risk of injury.*
 - f) **Do not expose a battery pack or tool to fire or excessive temperature.** *Exposure to fire or temperature above 130 °C may cause explosion.*
 - g) **Follow all charging instructions and do not charge the battery pack or tool outside the temperature range specified in the instructions.** *Charging improperly or at temperatures outside the specified range may damage the battery and increase the risk of fire.*
- 6) Service**
- a) **Have your power tool serviced by a qualified repair person using only identical replacement parts.** *This will ensure that the safety of the power tool is maintained.*
 - b) **Never service damaged battery packs.** *Service of battery packs should only be performed by the manufacturer or authorized service providers.*

- 1. **Hold the power tool by insulated gripping surfaces, when performing an operation where the fastener may contact hidden wiring.** *Fasteners contacting a "live" wire may make exposed metal parts of the power tool "live" and could give the operator an electric shock.*

SAFETY WARNINGS FOR BATTERY PACK

- a) **Do not dismantle, open or shred cells or battery pack.**
- b) **Do not short-circuit a battery pack. Do not store battery packs haphazardly in a box or drawer where they may short-circuit each other or be short-circuited by conductive materials.** *When battery pack is not in use, keep it away from other metal objects, like paper clips, coins, keys, nails, screws or other small metal objects, that can make a connection from one terminal to another. Shorting the battery terminals together may cause burns or a fire.*
- c) **Do not expose battery pack to heat or fire. Avoid storage in direct sunlight.**
- d) **Do not subject battery pack to mechanical shock.**
- e) **In the event of battery leaking, do not allow the liquid to come into contact with the skin or eyes. If contact has been made, wash the affected area with copious amounts of water and seek medical advice.**
- f) **Keep battery pack clean and dry.**
- g) **Wipe the battery pack terminals with a clean dry cloth if they become dirty.**
- h) **Battery pack needs to be charged before use. Always refer to this instruction and use the correct charging procedure.**
- i) **Do not maintain battery pack on charge when not in use.**
- j) **After extended periods of storage, it may be necessary to charge and discharge the battery pack several times to obtain maximum performance.**
- k) **Recharge only with the charger specified by Worx. Do not use any charger other than that specifically provided for use with the equipment.**
- l) **Do not use any battery pack which is not designed for use with the equipment.**
- m) **Keep battery pack out of the reach of**

SCREWDRIVER SAFETY WARNING



children.

- n) Retain the original product literature for future reference.
- o) Remove the battery from the equipment when not in use.
- p) Dispose of properly.
- q) Do not mix cells of different manufacture, capacity, size or type within a device.
- r) Keep the battery away from microwaves and high pressure.

SYMBOLS

	To reduce the risk of injury, user must read instruction manual
	Warning
	Wear ear protection
	Wear eye protection
	Wear dust mask

 Li-Ion  Li-Ion  Li-Ion 	<p>Li-Ion battery. This product has been marked with a symbol relating to 'separate collection' for all battery packs and battery pack. It will then be recycled or dismantled in order to reduce the impact on the environment. Battery packs can be hazardous for the environment and for human health since they contain hazardous substances.</p>
	Batteries may enter water cycle if disposed improperly, which can be hazardous for ecosystem. Do not dispose of waste batteries as unsorted municipal waste.
	Do not burn
	Wear protective gloves
	High speed
	Low speed
	Lock
	Screwdriving

	Waste electrical products must not be disposed of with household waste. Please recycle where facilities exist. Check with your local authorities or retailer for recycling advice.
	RCM marking
	ABN: Australian Business Number. By this number, business information such as entity type, status, business location etc. can be found at website http://abr.business.gov.au . ABN of Positec Australia Pty Limited is 14 101 682 357

COMPONENT LIST

1. FORWARD/ REVERSE ROTATION CONTROL

2. SOFT GRIP HANDLE

3. BATTERY PACK RELEASE BUTTON

4. BELT HOOK

5. BATTERY PACK*

6. LED LIGHT

7. ON/OFF SWITCH WITH VARIABLE SPEED CONTROL

8. COLLET LOCKING SLEEVE

9. BIT CLIP

* Not all the accessories illustrated or described are included in standard delivery.

TECHNICAL DATA

Type designation **WX291 WX291.X (2 - designation of machinery, representative of screwdriver)**

	WX291 WX291.X **
Rated voltage	20V  Max***
No-load speed	0-2600/min
Impact rate	0-3300bpm
Max torque	170N.m

Chuck capacity	6.35mm
Machine weight (bare tool)	1.09kg

* X=1-999, A-Z, M1-M9 there are only used for different customers, there are no safe relevant changes between these models.

*** Voltage measured without workload. Initial battery voltage reaches maximum of 20 volts. Nominal voltage is 18 volts.

SUGGESTED BATTERIES AND CHARGERS

Category	Type	Capacity
20V Battery	WA3551	2.0Ah
	WA3551.1	2.0Ah
	WA3553	4.0Ah
20V Charger	WA3760	0.4A
	WA3860	2.0A
	WA3880	2.0A

We recommend that you purchase your accessories from the same store that sold you the tool. Choose the type according to the work you intend to undertake. Refer to the accessory packaging for further details. Store personnel can assist you and offer advice.

NOISE INFORMATION

A weighted sound pressure $L_{pA} = 81.7\text{dB(A)}$

$K_{pA} = 3\text{dB(A)}$

A weighted sound power $L_{WA} = 92.7\text{dB(A)}$

$K_{WA} = 3\text{dB(A)}$

Wear ear protection.

VIBRATION INFORMATION

Vibration total values (triax vector sum) determined according to EN 62841:

Vibration emission value:

$a_h = 8.946\text{m/s}^2$ Uncertainty $K = 1.5\text{m/s}^2$

The declared vibration total value and the declared noise

emission value have been measured in accordance with a standard test method and may be used for comparing one tool with another.

The declared vibration total value and the declared noise emission value may also be used in a preliminary assessment of exposure.

WARNING: The vibration and noise emissions during actual use of the power tool can differ from the declared value depending on the ways in which the tool is used especially what kind of workpiece is processed dependant on the following examples and other variations on how the tool is used:

How the tool is used and the materials being cut or drilled. The tool being in good condition and well maintained. The use of the correct accessory for the tool and ensuring it is sharp and in good condition.

The tightness of the grip on the handles and if any anti vibration and noise accessories are used.

And the tool is being used as intended by its design and these instructions.

This tool may cause hand-arm vibration syndrome if its use is not adequately managed.

WARNING: To be accurate, an estimation of exposure level in the actual conditions of use should also take account of all parts of the operating cycle such as the times when the tool is switched off and when it is running idle but not actually doing the job. This may significantly reduce the exposure level over the total working period.

Helping to minimise your vibration and noise exposure risk.

Always use sharp chisels, drills and blades.

Maintain this tool in accordance with these instructions and keep well lubricated (where appropriate).

If the tool is to be used regularly then invest in anti vibration and noise accessories.

Plan your work schedule to spread any high vibration tool use across a number of days.

OPERATING INSTRUCTIONS



NOTE: Before using the tool, read the instruction book carefully.

INTENDED USE

This tool is intended for the fastening and loosening of bolts, nuts and various threaded fasteners. This tool is not intended for use as a drill.

ASSEMBLY AND OPERATION

ACTION	FIGURE
BEFORE OPERATION	
Removing the battery pack	See Fig. A1
Charging the battery Pack	See Fig. A2
Installing the battery pack	See Fig. A3
ASSEMBLY AND ADJUSTMENT	
Assembling the Belt Hook and Bit Clip	See Fig. B1, B2, B3, B4
Inserting the Bits	See Fig. C1
Removing the Bits	See Fig. C2
Forward / Reverse / Lock WARNING: Never change the direction of rotation when the chuck is rotating, wait until it is stopped!	See Fig. D1, D2, D3
OPERATION	
Operating the On/Off Switch WARNING: Do not operate for long periods at low speed because excess heat will be produced internally.	See Fig. E

LED Light Indicator

Before operation, the light will be activated when the On/Off switch is slightly depressed, and will automatically turn off 10 seconds after the On/Off switch is released.

The tool and battery are equipped with a protection system. The Light will quickly flash (approximately once a second, and stop flashing when you release the trigger), the system will automatically cut off power to the tool to extend battery life. The tool will automatically stop during operation if the tool and/or battery are placed under one of the following conditions:

● **Overloaded:** The tool is operated in a manner that causes it to draw an abnormally high current. In this situation, release the Trigger Switch on the tool and stop the application that caused the tool to become overloaded. Then pull the Trigger Switch again to restart.

● **Overheated:** Under the condition above, if the tool does not start, the Tool and Battery are overheated. In this situation, let the Tool and Battery cool before pulling the Trigger Switch again.

● **Low battery voltage:** The remaining Battery capacity is too low and the tool will not operate. In this situation, remove and recharge the Battery.

 **WARNING:** To turn on the light, press the On/Off switch and make sure the Forward/Reverse Rotation Control is on right/left position.

affect performance.

MAINTENANCE

Remove the battery pack from the tool before carrying out any adjustment, servicing or maintenance.

Your power tool requires no additional lubrication or maintenance.

There are no user serviceable parts in your power tool. Never use water or chemical cleaners to clean your power tool. Wipe clean with a dry cloth. Always store your power tool in a dry place. Keep the motor ventilation slots clean. Keep all working controls free of dust. Occasionally you may see sparks through the ventilation slots. This is normal and will not damage your power tool.

FOR BATTERY TOOLS

The ambient temperature range for the use and storage of tool and battery is 0°C-45°C.

The recommended ambient temperature range for the charging system during charging is 0°C-40°C.

See Fig. E

Positec Australia Pty Limited
10 Corporate Blvd Bayswater, VIC 3153, Australia

TROUBLE SHOOTING

1. I CAN NOT FIT THE BATTERY INTO THE BATTERY CHARGER. WHY?

The battery can be inserted into the charger only in one direction. Turn the battery around until it can be inserted into the slot.

2. REASONS FOR DIFFERENT BATTERY PACK WORKING TIMES

Charging time problems, as above, and having not used a battery pack for a prolonged time will reduce the battery pack working time. This can be corrected after several charge and discharge operations by charging & working with your drill. Heavy working conditions such as large screws into hard wood will use up the battery pack energy faster than lighter working conditions. Do not re-charge your battery pack below 0°C and above 40°C as this will

DECLARATION OF CONFORMITY

We,
Positec Germany GmbH
Postfach 32 02 16, 50796 Cologne, Germany

On behalf of Positec declare that the product
Description **Battery operated screwdriver**
Type designation **WX291 WX291.X (2 - designation of machinery, representative of screwdriver)**
Function **Tightening and loosening screws, nuts**

Complies with the following Directives:

2006/42/EC
2014/30/EU
2011/65/EU&(EU)2015/863

Standards conform to

EN 62841-1
EN 62841-2-2
EN 55014-1
EN 55014-2

The person authorized to compile the technical file,

Name Marcel Filz
Address Positec Germany GmbH
Postfach 32 02 16, 50796 Cologne, Germany

12



2022/1/4
Allen Ding
Deputy Chief Engineer, Testing & Certification
Positec Technology (China) Co., Ltd
18, Dongwang Road, Suzhou Industrial
Park, Jiangsu 215123, P. R. China

DECLARATION OF CONFORMITY

We,
Positec (UK & Ireland) Ltd.
PO Box 6242, Newbury, RG14 9LT, UK

On behalf of Positec declare that the product
Description **Battery operated screwdriver**
Type **designation WX291 WX291.X (2 - designation of machinery, representative of screwdriver)**
Function **Tightening and loosening screws, nuts**

Complies with the following regulations:
Supply of Machinery (Safety) Regulations 2008
Electromagnetic Compatibility Regulations 2016
The Restriction of the Use of Certain Hazardous Substances in Electrical and Electronic Equipment Regulations

Standards conform to
BS EN 62841-1, BS EN 62841-2-1,
BS EN 55014-1, BS EN 55014-2

The person authorized to compile the technical file,
Name Jim Kirkwood
Address Positec (UK & Ireland) Ltd.,
PO Box 6242, Newbury, RG14 9LT, UK



2022/1/4
Allen Ding
Deputy Chief Engineer, Testing & Certification
Positec Technology (China) Co., Ltd
18, Dongwang Road, Suzhou Industrial
Park, Jiangsu 215123, P. R. China







After-sales Service and Application

At www.worx.com you can order spare parts or arrange the collection of a product in need of servicing or repair.

Tel. Service: 0345 202 9679

E-Mail: customerservices@worxtools.com

www.worx.com

Copyright © 2022, Positec. All Rights Reserved.
AR01451502