

WORX NITRO

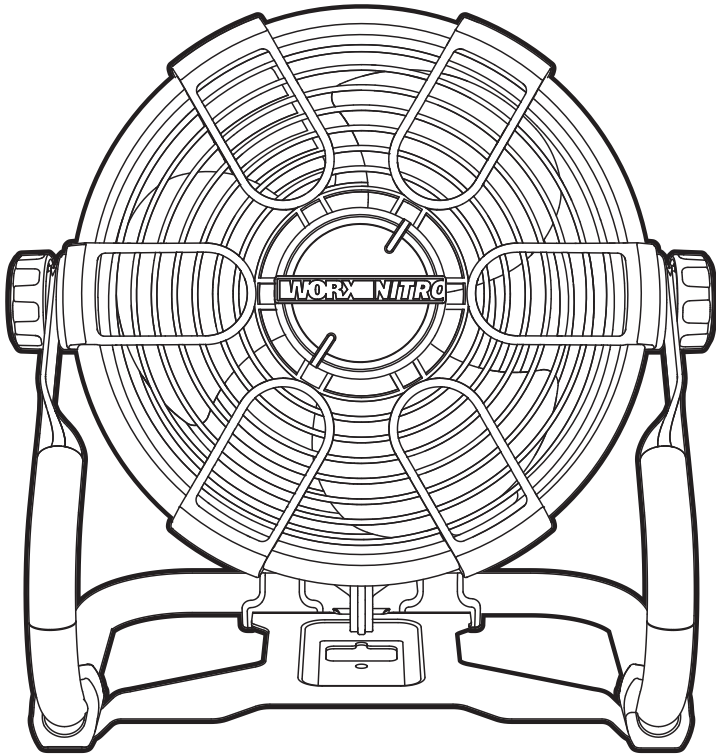

SAFETY AND OPERATING MANUAL

20V Jobsite Fan

WX095 WX095.X



PRODUCT SAFETY GENERAL SAFETY WARNINGS

⚠ WARNING: Read all safety warnings and all instructions. *Failure to follow the warnings and instructions may result in electric shock, fire and/or serious injury.*

Save all warnings and instructions for future reference.

This appliance can be used by children aged from 8 years and above and persons with reduced physical, sensory or mental capabilities or lack of experience and knowledge if they have been given supervision or instruction concerning use of the appliance in a safe way and understand the hazards involved. Children shall not play with the appliance. Cleaning and user maintenance shall not be made by children without supervision.

The appliance is only to be used with the power supply unit provided with the appliance.

If the supply cord is damaged, it must be replaced by the manufacturer, its service agent or similarly qualified persons in order to avoid a hazard.(for charger)

FAN SAFETY WARNINGS

1. Ensure that the fan is switched off and remove the battery before removing the guard.
2. If it is necessary to replace the live or neutral brushes to ensure operation of the motor then both brushes and the earth brush shall be replaced at the same time. The brushes shall only be replaced by a suitably qualified person.

SAFETY WARNINGS FOR BATTERY PACK

- a) **Do not dismantle, open or shred cells or battery pack.**
- b) **Do not short-circuit a battery pack. Do not store battery packs haphazardly in a box or drawer where they may short-circuit each other or be short-circuited by conductive**

materials. When battery pack is not in use, keep it away from other metal objects, like paper clips, coins, keys, nails, screws or other small metal objects, that can make a connection from one terminal to another.

Shorting the battery terminals together may cause burns or a fire.

- c) **Do not expose battery pack to heat or fire. Avoid storage in direct sunlight.**
- d) **Do not subject battery pack to mechanical shock.**
- e) **In the event of battery leaking, do not allow the liquid to come into contact with the skin or eyes. If contact has been made, wash the affected area with copious amounts of water and seek medical advice.**
- f) **Keep battery pack clean and dry.**
- g) **Wipe the battery pack terminals with a clean dry cloth if they become dirty.**
- h) **Battery pack needs to be charged before use. Always refer to this instruction and use the correct charging procedure.**
- i) **Do not maintain battery pack on charge when not in use.**
- j) **After extended periods of storage, it may be necessary to charge and discharge the battery pack several times to obtain maximum performance.**
- k) **Recharge only with the charger specified by Worx. Do not use any charger other than that specifically provided for use with the equipment.**
- l) **Do not use any battery pack which is not designed for use with the equipment.**
- m) **Keep battery pack out of the reach of children.**
- n) **Retain the original product literature for future reference.**
- o) **Remove the battery from the equipment when not in use.**
- p) **Dispose of properly.**
- q) **Do not mix cells of different manufacture, capacity, size or type within a device.**
- r) **Keep the battery away from microwaves and high pressure.**

GENERAL SAFETY WARNING FOR BATTERY CHARGER

WARNING: Read all  safety warnings and all instructions. Failure to follow the warnings and instructions may result in electric shock, fire and/or serious injury.

Save all warnings and instructions for future reference.

- This appliance is not intended for use by persons (including children) with reduced physical, sensory or mental capabilities, or lack of experience and knowledge, unless they have been given supervision or instruction concerning use of the appliance by a person responsible for their safety.
- Children should be supervised to ensure that they do not play with the appliance.

ADDITIONAL SAFETY INSTRUCTIONS FOR YOUR BATTERY CHARGER











1. Before charging, read the instructions.
2. For charge Li-ion battery pack only
3. Do not charge a leaking battery.
4. Do not use chargers for works other than those for which they are designed.
5. Before charging, ensure your charger is matching the local AC supply.
6. The charging device must be protected from moisture.
7. Do not use the charging device outdoors.
8. Do not short out the contacts of battery or charger.
9. Respect the polarity "+/-" when charging.
10. Do not open the unit and keep it out of the reach of children.
11. Do not charge the batteries of other manufactures or ill-suited models .
12. Ensure that the connection between the battery charger and battery is correctly positioned and is not obstructed by foreign bodies.
13. Keep battery charger's









slots free of foreign objects and protect against dirt and humidity. Store in a dry and frost-free place.

14. When charging batteries, ensure that the battery charger is in a well-ventilated area and away from inflammable materials. Batteries can get hot during charging. Do not overcharge any batteries. Ensure that batteries and chargers are not left unsupervised during charging.
15. Do not recharge non-rechargeable batteries, as they can overheat and break.
16. Longer life and better performance can be obtained if the battery pack is charged when the air temperature is between 18°C and 24°C. Do not charge the battery pack in air temperatures below 0°C, or above 40°C. This is important as it can prevent serious damage to the battery pack.
17. Charge only battery pack of the same model provided by Worx and of

models recommended by Worx.

SYMBOLS

	To reduce the risk of injury, user must read instruction manual
	Warning
	Double insulation (For Charger)
	For indoor use only (For Charger)
	Batteries may enter water cycle if disposed improperly, which can be hazardous for ecosystem. Do not dispose of waste batteries as unsorted municipal waste.
	Do not burn
	Li-Ion battery This product has been marked with a symbol relating to 'separate collection' for all battery packs and battery pack. It will then be recycled or dismantled in order to reduce the impact on the environment. Battery packs can be hazardous for the environment and for human health since they contain hazardous substances.
	Li-Ion
	SMPS (Switch mode power supply unit) (For Adaptor)
	SMPS incorporating a short-circuit-proof safety isolating transformer (inherently or non-inherently) (For Adaptor)

	SMPS incorporating a fail-safe safety isolating transformer (For Adaptor)
	Waste electrical products must not be disposed of with household waste. Please recycle where facilities exist. Check with your local authorities or retailer for recycling advice.
	Fuse (For Adaptor)
	Fuse (For Charger)
	Positive terminal (For Charger)
	Negative terminal (For Charger)
	The output plug is with positive center pole and negative outer pole (For Adaptor)
	RCM marking

ABN: Australian Business Number. By this number, business information such as entity type, status, business location etc. can be found at website <http://abr.business.gov.au>.
 ABN of Positec Australia Pty Limited is 14 101 682 357

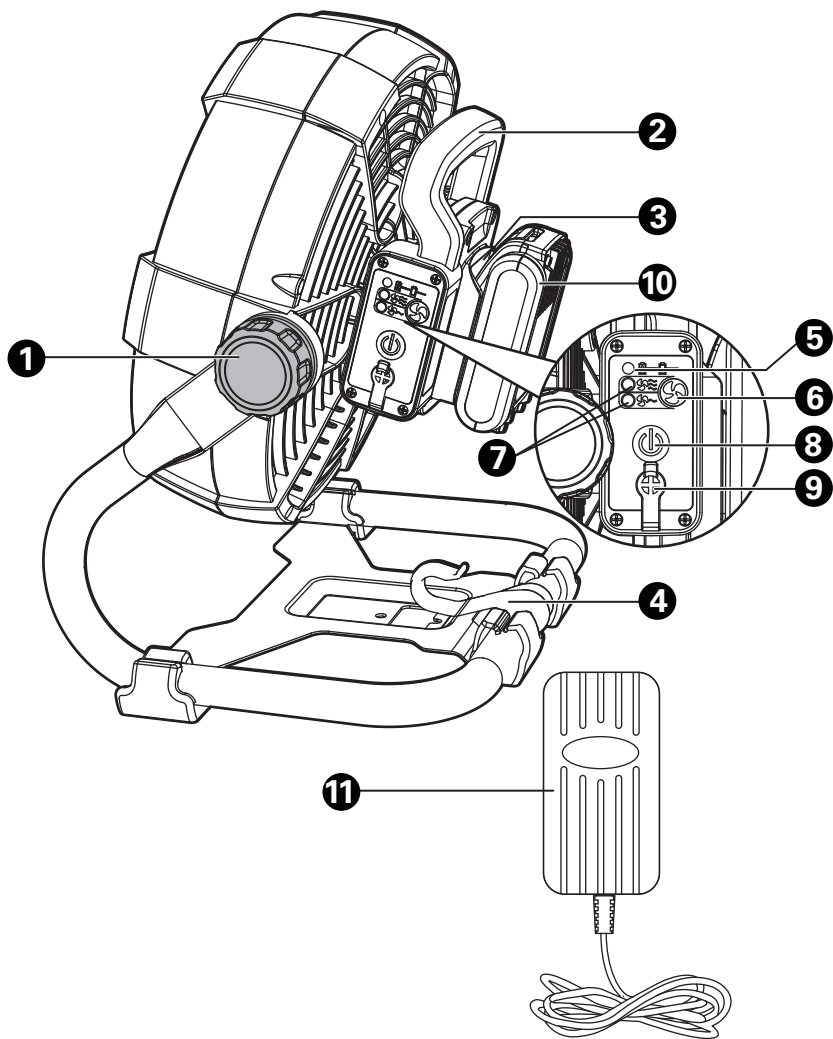

20V Jobsite Fan

WX095 WX095.X

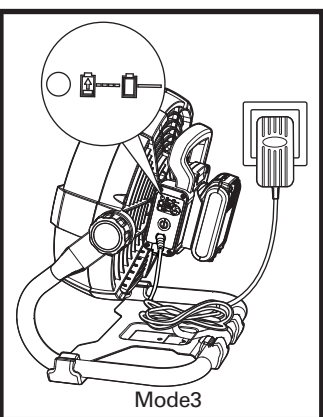
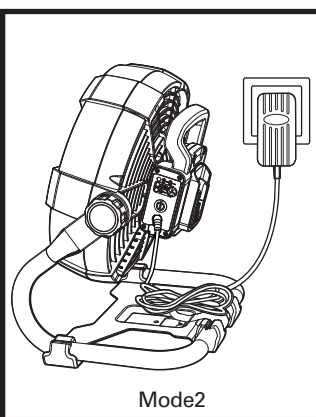
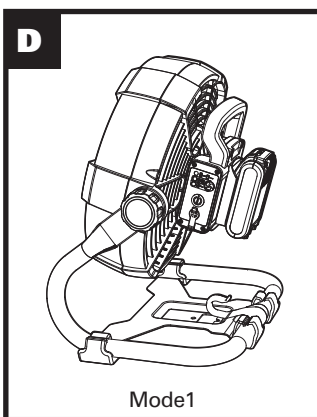
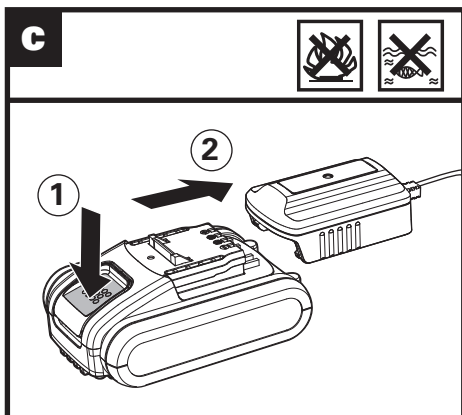
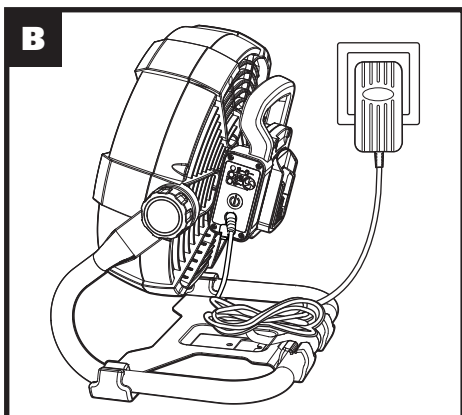
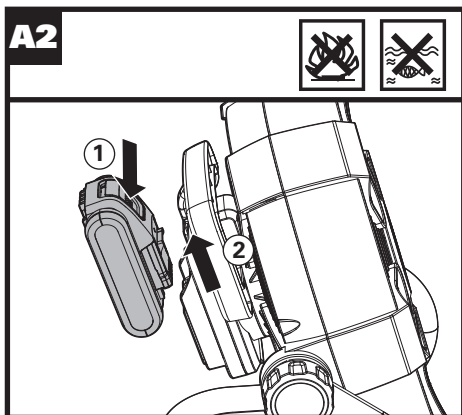
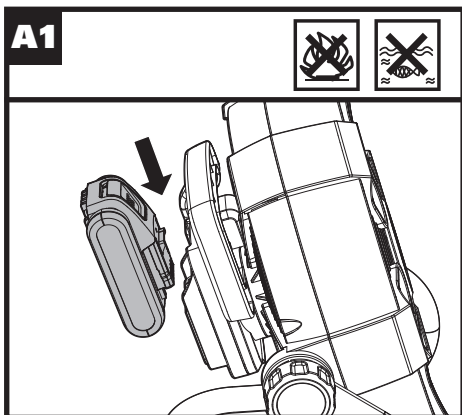

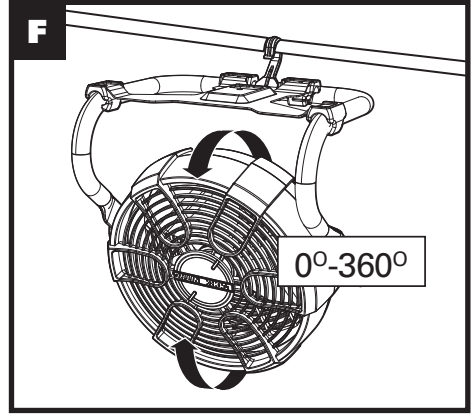
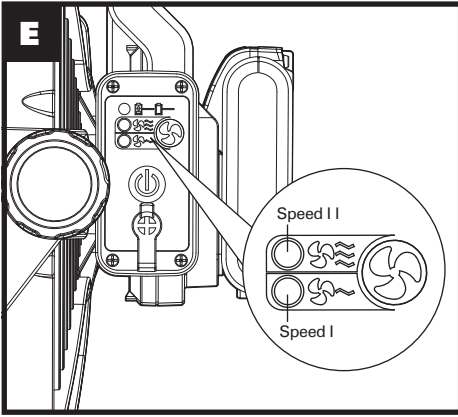



COMPONENT LIST

1.	POSITION ADJUSTMENT
2.	HANDLE
3.	BATTERY PACK PORT
4.	HOOK
5.	CHARGING INDICATOR LIGHT
6.	SPEED ADJUSTMENT BUTTON
7.	SPEED INDICATOR LIGHT
8.	POWER SWITCH
9.	AC ADAPTOR PORT
10.	BATTERY PACK*
11.	AC ADAPTOR

* Not all the accessories illustrated or described are included in standard delivery.

TECHNICAL DATA

	WX095 WX095.X**
Rated voltage	20V  MAX***
battery type	Li-Ion
AC adapter input	100-240V~50/60Hz 1.0A
AC adapter output	20V  1500mA
The ambient operating temperature	0°C-45°C
Machine weight (Bare Tool)	2.48kg

** X=1-999, A-Z, M1-M9 there are only used for different customers, there are no safe relevant changes between these models.

*** Voltage measured without workload. Initial battery voltage reaches maximum of 20 volts. Nominal voltage is 18 volts.

SUGGESTED BATTERIES AND CHARGERS

Category	Type	Capacity
20V Battery	WA3551	2.0Ah
	WA3551.1	2.0Ah
	WA3553	4.0Ah
20V Charger	WA3760	0.4A

We recommend that you purchase your accessories listed in the above list from the same store that sold you the charger. Refer to the accessory packaging for further details. Store personnel can assist you and offer advice.

OPERATION INSTRUCTION



NOTE: Before using the tool, read the instruction book carefully.







WARNING

Do not let your acquaintance with the tool allow you to get injured.



Never make use of attachments or accessories which are not recommended by manufacture.

ACTION	FIGURE
Installing or removing the battery pack / AC adaptor  Remember to remove battery pack or adaptor each-time when adjusting, cleaning or leaving tool unused. Confirm the adaptor is firmly in place and on level ground prior to using.	see figure A1, A2, B
Charging the battery pack Charging indicator light will be flashing green which means that the battery is being charged. When the battery is fully charged, the light will stay green without flashing (figure D(mode 3)) NOTE: If the fan is off, the battery will be fully charged in 1.5hr using the AC Adapter. If the fan is running on low speed, it will take approximately 2.0 hours to fully charge. If the fan is running on high speed, it will take approximately 4.0hrs to fully charge the connected battery. (figure D(mode 3))	see figure C, figure D(mode 3)



<p>Starting & Stopping Push the switch (8) button to start and stop the fan as needed.  Make sure that the switch is in the off position when the fan is not in use</p>	see figure D
<p>Change the speed For Low Speed/ High Speed, push the Speed adjustment button (6) to  /  and front light will turn on.</p>	see figure E
<p>Hanging the fan and Adjusting head  It is inadvisable to hang the fan in the ways that it will impede fan's operation and contribute to cord's damages. When hanging, be careful to secure the fan to avoid it from falling which could cause injury or damage.</p>	see figure F

MAINTAIN BATTERY CHARGER WITH CARE

Remove the plug from the socket before carrying out any adjustment, servicing or maintenance. Your battery charger requires no additional lubrication or maintenance. Never use water or chemical cleaners to clean your charger. Wipe clean with a dry cloth. Always store your charger in a dry place.
If the supply cord is damaged, it must be replaced by the manufacturer, its service agent or similarly qualified persons in order to avoid a hazard.

Positec Australia Pty Limited
10 Corporate Blvd Bayswater , VIC 3153,Australia

ENVIRONMENTAL PROTECTION

 Waste electrical products must not be disposed of with household waste. Please  recycle where facilities exist. Check with your local authorities or retailer for recycling advice.

MAINTENANCE

 **WARNING: Always remove or disconnect battery pack before adjusting, cleaning, servicing or transporting the fan.**

1). Cleaning and maintenance

1. Must wear eye protection. If not , the object may get into your eyes which may hurt you.
 2. Always take off battery pack and adaptor when maintaining the product in order to refrain from the injury.
 3. Do not put the finger, sticks or other similar objects into the fan in case of the injury or product's damage.
 4. Never let chemicals touch the plastic parts. Or else, the plastic parts will be damaged, causing irreversible personal injury
 5. Never try to damage any part of the battery pack and keep it away from children. The battery should be recycled and treated correctly.
- Not obey the warning above, serious consequence will be made, such as fire.

2). Storage

Store in a secure, dry place out of the reach of children.
Do not place other objects on the product. Employ only the same replacements for it may contribute to the damage of product when using other replacements.
Not recommend using the fan in the wet place outside the door.

DECLARATION OF CONFORMITY

We,
Positec Germany GmbH
Postfach 32 02 16, 50796 Cologne, Germany

Declare that the product
Description **Battery operated fan**
Type **WX095 WX095.X (095-designation of machinery, representative of Battery operated fan)**
Function **blowing**

Complies with the following Directives:

2014/30/EU
2011/65/EU&(EU)2015/863
2014/35/EU,

Standards conform to
EN 60335-1, EN 60335-2-80, EN 55014-1, EN 55014-2, EN 62233
EN 61558-1, EN 61558-2-16, EN IEC 61000-3-2, EN 61000-3-3
EN60950-1, EN60065



2022/06/10
Allen Ding
Deputy Chief Engineer, Testing & Certification
Positec Technology (China) Co., Ltd
18, Dongwang Road, Suzhou Industrial
Park, Jiangsu 215123, P. R. China

DECLARATION OF CONFORMITY

We,
Positec (UK & Ireland) Ltd
PO BOX 6242, Newbury, RG14 9LT, UK

Declare that the product
Description **Battery operated fan**
Type **WX095 WX095.X (095-designation of machinery, representative of Battery operated fan)**
Function **blowing**

Complies with the following regulations:
Electrical Equipment (Safety) Regulations 2016
Electromagnetic Compatibility Regulations 2016
The Restriction of the Use of Certain Hazardous Substances in Electrical and Electronic Equipment Regulations

Standards conform to
BS EN 60335-1, BS EN 60335-2-80, BS EN 55014-1, BS EN 55014-2, BS EN 62233
BS EN 61558-1, BS EN 61558-2-16, BS EN IEC 61000-3-2, BS EN 61000-3-3
BS EN60950-1, BS EN60065

14



2022/06/10
Allen Ding
Deputy Chief Engineer, Testing & Certification
Positec Technology (China) Co., Ltd
18, Dongwang Road, Suzhou Industrial
Park, Jiangsu 215123, P. R. China

20V Jobsite Fan

WX095 WX095.X





After-sales Service and Application

At www.worx.com you can order spare parts or arrange the collection of a product in need of servicing or repair.

Tel. Service: 0345 202 9679

E-Mail: customerservices@worxtools.com

www.worx.com

Copyright © 2022, Positec. All Rights Reserved.
V1-UK&AU-WX095 WX095.X-M-20220610